

Smart & compact design! Digital X-ray imaging system, PAPAAYA

Papaya: This smart design will allow for easy, fast setting and installation. Not only that, its compact design requires minimum space and is easily accessible for your patients.



Convenient accessory tray



User friendly LED indication



Comfortable hand grip



Even more, Tomography!
(optional)

TRIANA

TRIANA is able to manage all images from all devices.(panoramic, cephalometric, intraoral sensor, CBCT, intraoral camera and digital camera)

Image viewing	Zoom, Panning, Comparing, Window leveling	Measurement	Distance, Angle
Annotations	Line, Arrow, Text, Stamp		
Implant simulation, DICOM 3.0 compatibility	Storage (DICOM send), film printer, worklist etc		
Image enhancement, Printing	Paper, Film printer, WYSWYG	Image import/export	bmp, jpg, gif, png, dcm etc



Technical Specifications

GENERAL	PAPAYA
Exposure Time	4 ~ 17 sec
Focal Spot	0.5mm
Target Angle	5°
Tube Voltage	60~90kV
Anode Heat Storage Capacity	35kJ
Maximum Anode Heat Dissipation Rate	250W
Line Voltage	220 V, 50/60Hz

SENSOR	
Detector Technology	CMOS / CsI
Data Interface	Giga Ethernet
Pixel Pitch	75um x 75um
Active Area	150 x 6.45mm

CUST	
X-ray beam	fan beam
Volumetric image size	50 x 50 x 103 mm
Number of slices	256
Slice thickness	0.195 mm

* The specifications above can be changed to improve performance without notice.

Dimensions

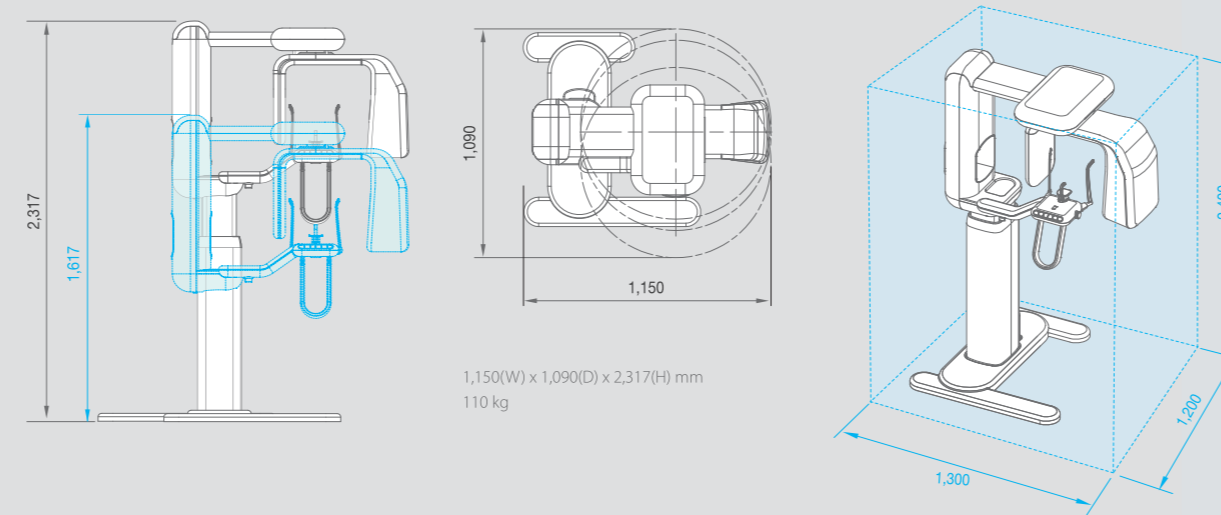

Choose your own PAPAAYA Serie

	PAPAYA	PAPAYA PLUS	PAPAYA 3D	PAPAYA 3D PLUS
Panoramic	●	●	●	●
3D Imaging			●	●
CUST Imaging	●	●		
Cephalometric		●		●

GENORAY Co.,Ltd.
512, 560, Dunchon-daero, Jungwon-gu, Seongnam-si,
Gyeonggi-do, 462-716, Korea
Tel : +82-31-627-3900 Fax : +82-31-737-8016
genoray@genoray.com

www.genoray.com

Genoray America Inc.
147 E. Bristol Lane Orange, CA 92865 USA

Genoray EU GmbH
Westhafenstr. 1 13353 Berlin, Germany

Genoray Japan
2F Ishibashi-Bldg, 1-4-15 Shinyokohama,
Kohhoku-ku, Yokohama-city, Kanagawa, 222-0033 Japan



2460

PAPAYA
Dental X-ray Imaging system

Panoramic Imaging
&
Tomography Imaging

Panoramic Imaging

High Resolution X-ray Imaging system







PAPAYA uses the advanced CMOS sensor, which improves image quality while keeping radiation exposure to a minimum, Genoray has shown that it puts patient's safety first.



Multi-Focus Function

The Multi-focus function can overcome patient mis-positioning. The user is therefore able to find the most optimally-focused choice from a selection of images.



-  Face to face positioning
-  Hand switch
-  Jaw Shape
-  Emergency switch
-  Voice support system
-  Wheelchair accessible

Exposure Programs

PAPAYA supports various exposure programs, fulfilling all diagnostic needs. Standard panoramic, orthogonal panoramic, bitewing panoramic, child panoramic, TMJ lateral double, horizontal & vertical X-ray segmentation, TMJ PA double, TMJ LAT-PA, TMJ LAT-PA double, sinus lateral and sinus PA are supported.



Standard panoramic



Orthogonal panoramic

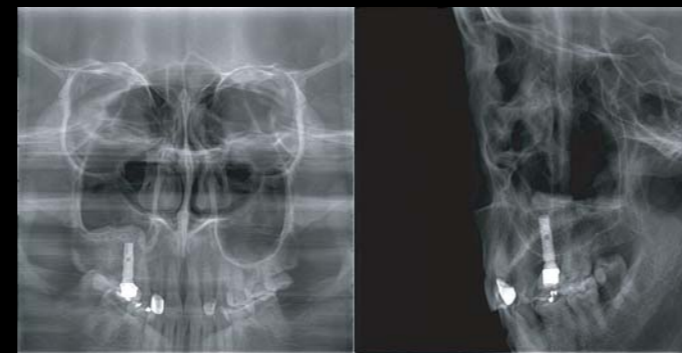

Sinus PA / Sinus lateral midsagittal

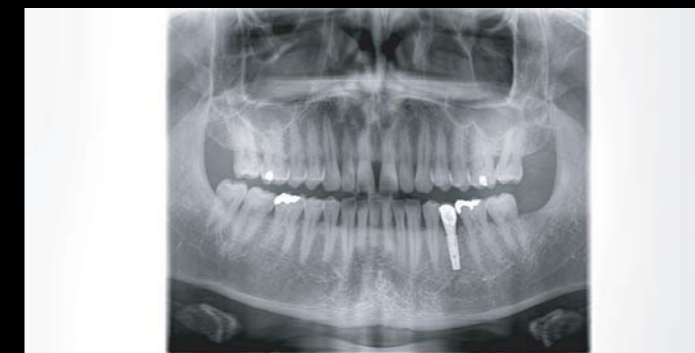

X-ray segment



Bitewing



TMJ lateral double

Tomography Imaging ^(Optional)

CUST (Cubical Semi Tomography Technology)

PAPAYA CUST is in a 3D imaging function that provides cross-sectional information for implant preparation.

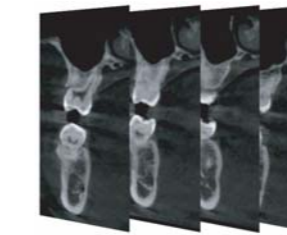

- High image quality due to statistical reconstruction technique.
- 3D image has 256 cross-sectional slices having 0.195mm thickness and has FOV 50x50x103mm.

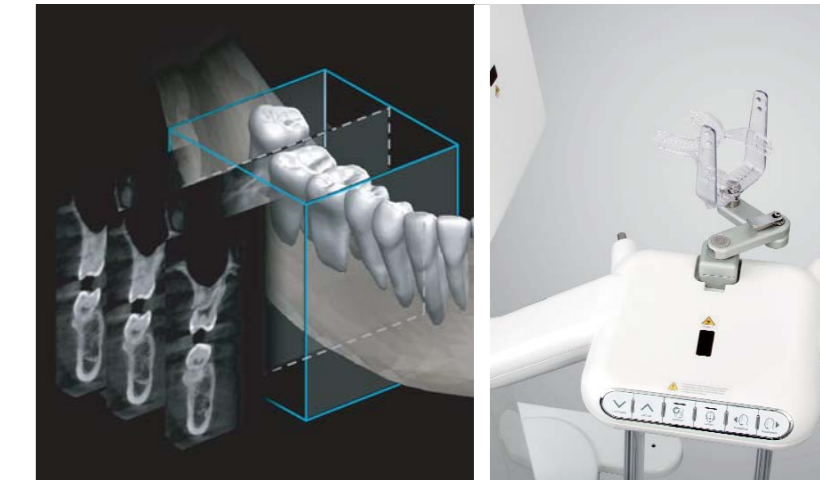

- Complements the panoramic image, and provides a tomographic image required for implant planning.
- When planning the implant, CUST images help the patient understand the procedure. (Minimal investment, Maximal benefit)
- PAPAYA with CUST function is economical compared to CBCT.

Exposure Programs

